



Santoemma

Professional Cleaning Machines



Since 1980



CARPET

Professional Cleaning Program

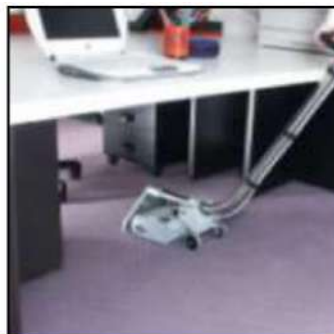

The Santoemma Method for Carpet Professional Cleaning

The Santoemma CARPET program includes the widest range of machines and accessories for professional carpet cleaning, developed to solve cleaning problems in any size area. The whole range is characterized by reliability and robustness.

Santoemma has developed its own **method** for the professional cleaning of carpeted areas that achieves better results than any other system available. The following points are focussed on:

- **Quality results:** the carpet is clean like new and it gets dirty again slowly, like a brand new carpet
- Extremely reduced **drying time:** the carpet can be **dry in 1 hour!**
- **User-friendly** cleaning operations: the operator's time and effort is considerably decreased

The Santoemma Method incorporates all the cleaning factors within carpet cleaning and uses them simultaneously and optimally: **chemical action, mechanical action, temperature, time** and **vacuuming**.

Each factor has been optimized by the design of Santoemma special systems and devices that are added to a basic injection-extraction machine, transforming it into a "**Professional SET**" for carpet cleaning.

Injection-extraction system

With the injection-extraction system, a solution of water and chemical is sprayed into the carpet's fibres and immediately sucked out. The solution and the dirt that is removed are recovered directly into the dirty water tank of the machine. With this method, it would usually take many passes on the same carpet area to complete the cleaning process.

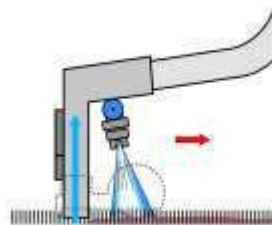

HIGH WATERLIFT technology

The drying time of the carpet after cleaning greatly depends on the vacuum strength. A specially designed high waterlift vacuum system has been developed for Santoemma machines, which allows them to get up to 50% higher waterlift than standard carpet extractors. It is possible to recover up to 95% of the sprayed solution.

This results in an extremely shorter **drying time** than with normal carpet extractors. Not only is the drying time reduced, but also a **better cleaning result** is obtained. This is due to the extra solution extracted from the carpet fibres, containing extra dirt that was in the carpet. The same residual dirty solution, if left evaporating in the carpet as it usually happens, would leave the carpet not so clean as with Santoemma machines.

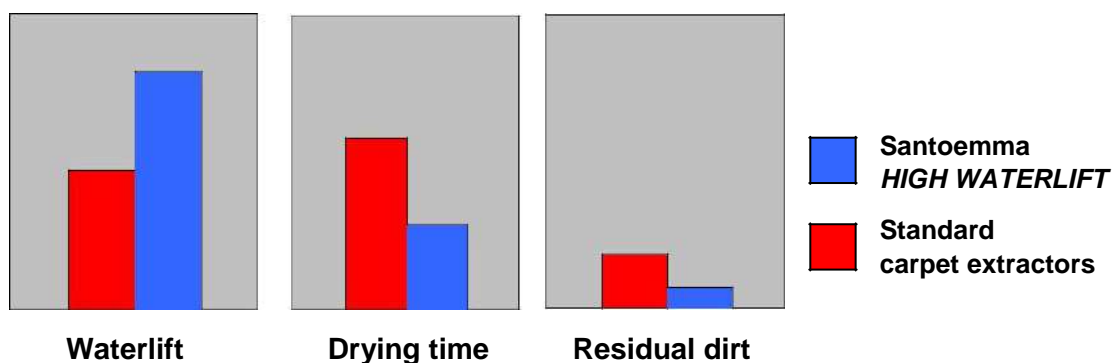

Injection-extraction system with mechanical brushing action

The cleaning result is improved with the mechanical action of a rotating cylindrical brush. This allows complete cleaning of each fibre by removing dirt from the base of the carpet fibres, which otherwise resurfaces a few days after cleaning. The mechanical action of the brush is therefore essential to obtain a professional result.

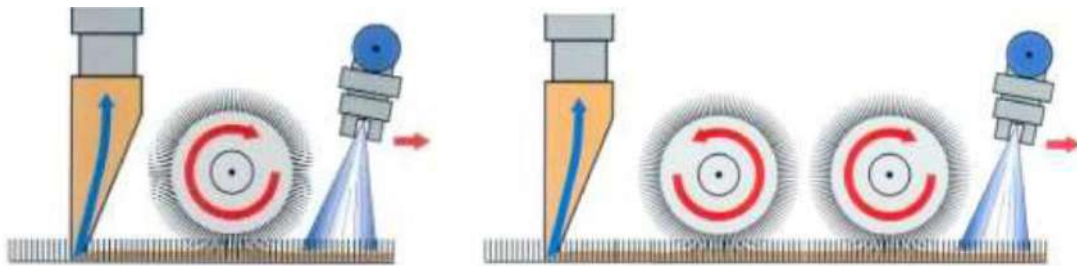

Instant hot water system



In carpet and textiles cleaning, the cleaning result can be improved by using a hot solution, instead of room temperature solution. Specific tests show that cleaning carpet with just 10°C more can give the same result as cleaning twice. The **Santoemma instant heating system** provides hot water immediately after switching the machine on. It is not necessary to wait a long time until the whole solution tank gets warm, as it happens with other hot water machines on the market.

Carpet pre-spraying

A pre-spray of a concentrated chemical solution is usually recommended before starting cleaning. The extended contact time of the chemical assists the removal of dirt from the fibres, therefore achieving better cleaning results and reducing the time spent on the subsequent cleaning operations.

Sometimes the pre-spray is done using manual or electrical pre-treatment devices, which are separate and extra machines. Santoemma has developed the **SMARTKIT, a patented device** that allows the pre-spray process to be done by the same machine used to clean.

During the pre-spray process, the sprayed solution is very concentrated. This provides the appropriate quantity of chemical, without overwetting the carpet. Thanks to the machine pump's high performance, the operator can pre-spray surfaces very fast. Because the operator can use the complete solution tank for the pre-spray, a greater area can be sprayed and time saved by not filling up separate portable pre-spray devices.



Grace-Silent equipped with SMARTKIT and pre-spray tool

The Santoemma Method for Carpet Professional Cleaning

Automatic chemical dosing

The solution of water and chemical is usually obtained by directly adding chemical into the solution tank. To get the correct concentration, it is necessary to calculate the quantity of chemical to be added, according to the solution tank capacity. After cleaning, the residual solution in the tank is normally wasted.

The SMARTKIT system allows the chemical to be automatically mixed during the cleaning process. This always provides the correct mixture without wasting any chemical.

Carpet rinsing to remove chemical residue

After cleaning a carpet with chemical, it is recommended to rinse it afterwards. This is in order to remove any sticky residue that is left, which causes the carpet to re-soil quickly.

The rinsing phase, though important, is only seldom performed because of the time it requires: it would be necessary to drain the complete tank and fill it with clean water only.

For Santoemma models equipped with the SMARTKIT system, it is possible to rinse the carpet by simply turning a lever. Therefore no chemical is wasted and time is saved. Rinsing the carpet at the end of the cleaning process will make it re-soil as slowly as if it was new.

The average dirt level (A.D.L.) of the carpet is much lower between one cleaning and the next.

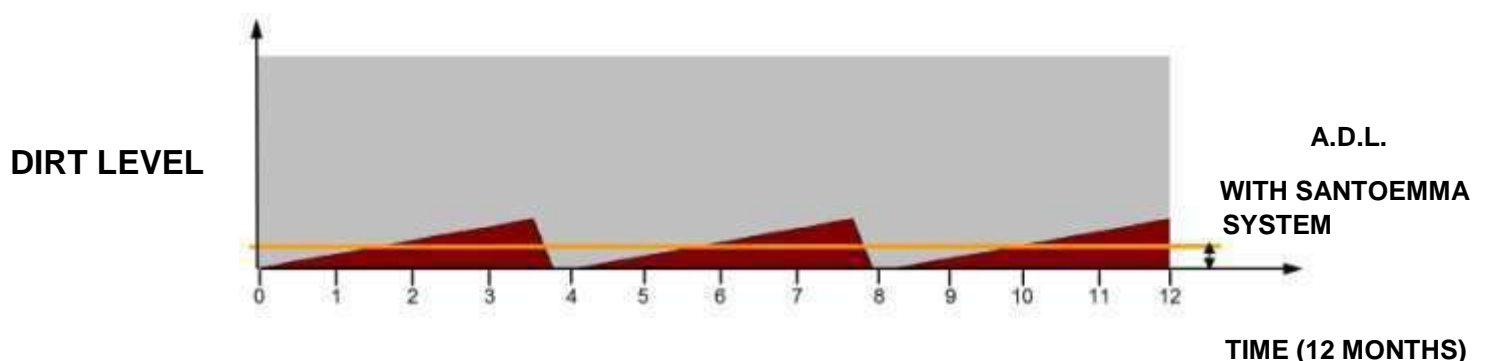
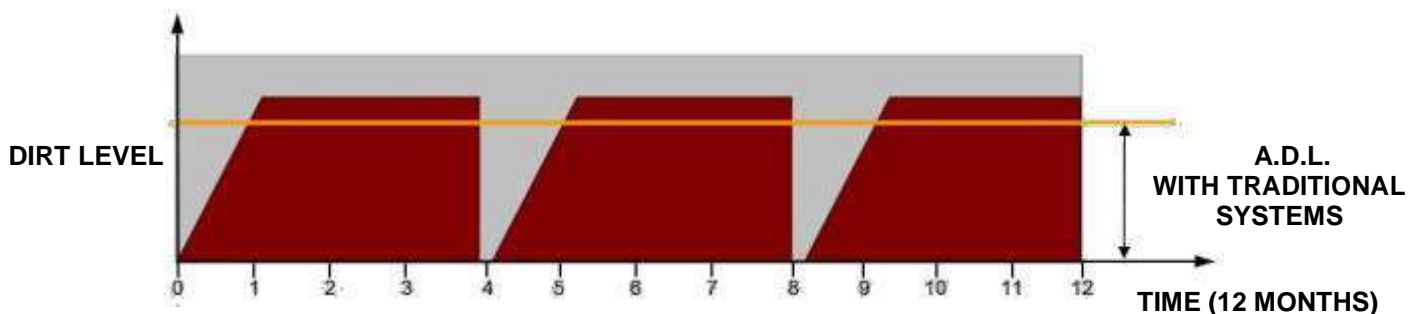

Maintenance and restorative deep-cleaning

Santoemma machines are able to work both in **maintenance** and **restorative deep cleaning** modes. This is set according to the quantity of dirt to remove and the lapse of time from the previous cleaning.

For a restorative deep cleaning, a water jet, sufficient to completely clean even a very dirty carpet, is sprayed. For maintenance cleaning a reduced quantity of water is sprayed.

Lower consumption of water and shorter drying time

With the combined use of mechanical action, high temperature and extended chemical action the cleaning effectiveness improves considerably. Therefore a strip of carpet can be cleaned with a **single pass**, rather than with many passes as it happens with the traditional injection-extraction system.



As a result, **water usage** is decreased by up to **75%** compared to the basic injection-extraction system.

Moreover the high waterlift vacuum system allows recovering a higher percentage of water than traditional injection-extraction machines (about 90% against 80%).

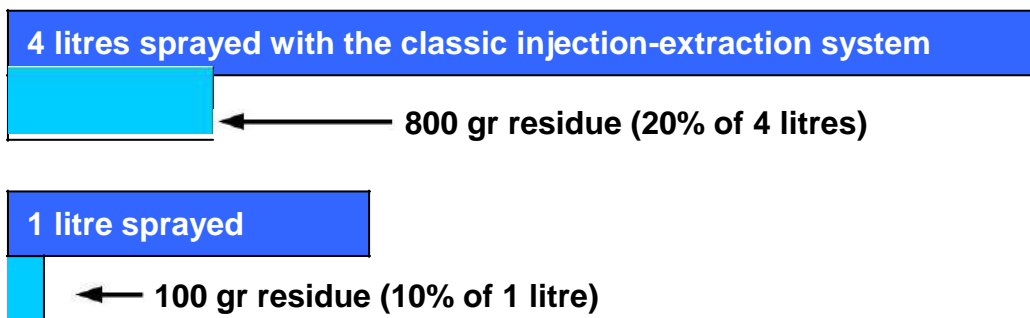

After cleaning, the residual solution in the carpet fibres is therefore greatly reduced and the drying time is extremely shortened: the carpet can be **dry in 1 hour!**

Reduced consumption and environmental respect

Using the Santoemma method, the time it takes to clean 1 square metre is reduced by up to **67%** and much less effort is required from the operator. The use of **water** and **chemical** can also be reduced by up to **80%**. All these features coincide with the growing demand of the cleaning sector to be responsible in the use of resources involved in the cleaning process.

The right machine for each area: BOX or SELF-CONTAINED machines



Box extractors are composed of the machine body, hoses and an external wand used to spray and vacuum the carpet.



Self-contained machines incorporate the cleaning unit below the machine body. The operator moves the machine on the carpet surface, cleaning parallel carpet strips, which achieves a higher performance in terms of square metres cleaned per hour. External tools can also be used to clean hard-to-reach areas.



Box extractors

Box extractors are composed of the machine body, hoses and an external wand used to spray and vacuum the carpet. Santoemma has developed unique systems and incorporated special technologies, allowing them to get the best cleaning results with the maximum performance. By adding the special options, a Santoemma box extractor can be transformed into a “**Professional carpet cleaning set**”, which combines all the cleaning factors in an optimal way, giving incomparable cleaning results. Cleaning can be performed with a cold or a hot chemical solution, which is instantly created by the machine. An optional power-brush wand can be used instead of the normal wand. This increases the performance, enhances the cleaning result and removes the dirt from the base of carpet fibres. Finally, the patented SMARTKIT system makes it possible to perform carpet pre-spray with concentrated chemical solution, automatic chemical dosing and carpet rinsing.



The **Sabrina** is specially designed to clean small areas of carpet and hard floors. Even though it is compact, the Sabrina is suitable for professional use. It is also suitable for demanding market sectors such as the rental market or cleaning services. Its **high-waterlift** vacuum system allows it to recover the maximum quantity of dirt from the carpet as well as achieving the shortest drying time possible. When equipped with the optional rotating brush wand, the NS270BRUSH, Sabrina can get excellent cleaning results. The Sabrina is supplied with a wand for carpet and hard floor, the NS270N. The NS10PN is an optional hand tool for cleaning upholstery and car interiors. With the NS270TURBODUST, which is another optional accessory, the Sabrina works as a vacuum cleaner as well. Thanks to the filter inside this accessory, there is no need to make any change to the machine to operate a different function.

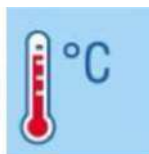
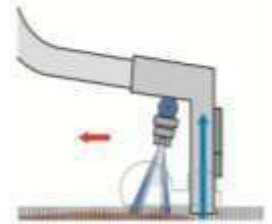

The **Sabrina-Hot** is the smallest extractor with instant water heating. The use of hot water allows a more effective cleaning of very dirty textiles. Moreover, its **high-waterlift** vacuum system allows it to recover the maximum quantity of dirt from the carpet as well as achieving the shortest drying time possible. Sabrina-Hot can be loaded into a small car or carried to the top of the stairs without much effort, thanks to its compact size and low weight. Sabrina-Hot is supplied with the hand tool NS10PN which is standard and it can be also connected to the optional accessory, the NS270N, for cleaning carpets and hard floor. The Sabrina-Hot is suggested for those cleaning companies that need an easy-to-carry hot water extractor.

Box extractors

7



Up to
80
sqm/h



The **Sabrina-Maxi** is a professional machine for cleaning medium areas of carpets. Its **high-waterlift** vacuum system allows it to recover the maximum quantity of dirt from carpets and to achieve a short drying time.

Strong, compact and easy to carry, this machine is ideal for cleaning companies. Its small width makes it also particularly suitable for cleaning in trains, busses, cinemas and planes. The Sabrina-Maxi can be supplied with the instant hot water unit HT1800 and with one of the optional power brush wands.

Optional hand-tools are available, in plastic (NS10PN) or in aluminium (NS10ALL). If equipped with the patented SMARTKIT system, it is possible to perform automatic chemical dosing, carpet pre-spraying and rinsing.

The **Serena-Silent** is a particularly quiet carpet extractor (only 60 decibel!). It has an excellent suction power, thanks to its three stages high-waterlift vacuum motor. Its **high-waterlift** vacuum system allows it to recover the maximum quantity of dirt from the carpet and to get the shortest drying time possible. Thanks to its quiet running, this machine is recommended for cleaning hotels, offices, banks, and any other noise-sensitive areas. Dedicated brackets allow for hanging hoses and the wand on the machine. This enables the operator to move the complete machine easily from site to site. The machine can be supplied with the instant hot water unit HT1800 and with one of the optional power brush wands. If equipped with the patented SMARTKIT system, it is possible to perform automatic chemical dosing, carpet pre-spraying and rinsing.

Up to
90
sqm/h



The **Grace-Silent** is a professional carpet extractor with 2 high-waterlift vacuum motors for the fast cleaning of large areas of carpets. Its **high-waterlift** vacuum system allows for the recovery of the maximum quantity of dirt from the carpet and the shortest drying time possible. The two tanks, 70 litres each, enable long periods of operation without emptying or refilling. Dedicated brackets allow for hanging hoses and the wand on the machine. This enables the operator to move the complete machine easily from site to site. The machine can be supplied with the instant hot water unit HT1800 and with one of the optional power brush wands. If equipped with the patented SMARTKIT system, it is possible to perform automatic chemical dosing, carpet pre-spraying and rinsing.

Up to
100
sqm/h



The **GraceHP-Silent** is a high-performance carpet extractor, with a 28 bar piston pump and 2 high-waterlift vacuum motors. Its **high-waterlift** vacuum system allows for the recovery of the maximum quantity of dirt from the carpet and for the shortest drying time possible. The high pressure flow allows easier dirt removal from the carpet fibres. The two tanks, 70 litres each, enable long periods of operation without emptying and refilling. GraceHP-Silent is particularly indicated for professional carpet cleaners. Dedicated brackets allow for hanging hoses and the wand on the machine. This enables the operator to move the complete machine easily from site to site. This machine can be supplied with the instant hot water unit HT1800-HP and with one of the optional power brush wands. GraceHP-Silent is supplied with an integrated and patented SMARTKIT system, allowing automatic chemical dosing, carpet pre-spraying and rinsing.





Special options

A series of special options can be added to each model of the Santoemma range, in order to enhance the cleaning performance of each machine. This is achieved by using the optimal combination of the essential carpet cleaning factors: temperature, chemical action, mechanical brushing action, time, vacuuming. By adding these special options, a Santoemma machine can be transformed into a “**Professional carpet cleaning SET**”, which combines all the cleaning factors in the most optimal way, giving incomparable cleaning results.

The **SMARTKIT** is a multiple patented system developed by Santoemma which gives many advantages in carpet cleaning. It is available for the following box extractors and self-contained machines: Sabrina-Maxi, Serena-Silent, Grace-Silent, GraceHP-Silent, Charis-ONE, Charis-DUAL, Elite-Silent, Powerful-Silent and Elite-Battery.



The SMARTKIT provides an **automatic chemical dosing** function, which ensures a correct chemical concentration and eliminates the manual dilution operations normally required by the user.

Moreover, using the pre-spray hose and gun, it is possible to perform **carpet pre-spraying** before cleaning, therefore achieving better cleaning results and reducing the time spent on the subsequent cleaning operations.

It is also possible to **rinse the carpet** after cleaning, removing all chemical residues from the carpet fibres, avoiding a fast re-soling of the carpet after cleaning.

Finally, by simply turning a lever it is also possible to quickly alternate between **maintenance cleaning** and **restorative deep cleaning**.

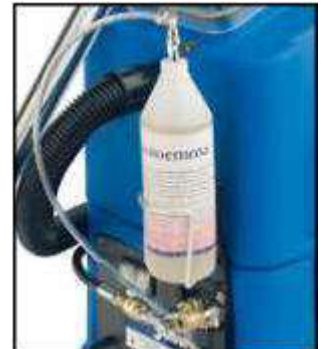

The instant heater HT1800 is an optional device that allows cleaning with hot water. It is available for the following box extractors and self-contained machines: Sabrina-Maxi, Serena-Silent, Grace-Silent, GraceHP-Silent, Charis-ONE, Charis-DUAL, Elite-Silent, Powerful-Silent.

Santoemma **instant heating system** provides hot water immediately after switching the machine on. It is not necessary to wait a long time until the whole solution tank gets warm, as it happens with other hot water machines on the market.

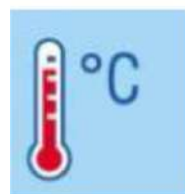

Special options



NS270BRUSH and **NS400BRUSH** are special wands, each having a cylindrical rotating brush. These can be used for cleaning carpet in combination with an injection-extraction machine. The mechanical brushing action allows the removal of dirt from the base of the carpet fibres. If there is residual dirt that is left on the base of the fibres, it resurfaces a few days after cleaning. Even a very dirty carpet is left completely clean in a single pass. Minimal water is used to clean the carpet, therefore the drying time is greatly reduced: the carpet can be dry in 1 hour.

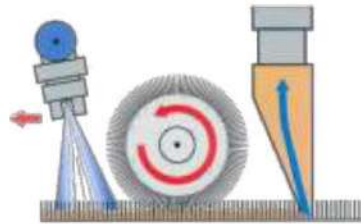

NS400BR-DUAL and **NS400BR-DUAL-HT** are special wands, with 2 counter-rotating cylindrical brushes each.

With the NS400BR-DUAL-HT an incorporated **instant heating system** allows instant heating of the cleaning solution that is sprayed on carpet. This wand is suggested for the Grace-Silent and GraceHP-Silent models in particular. The cleaning result is excellent, thanks to the combination of mechanical brushing action and temperature.

When using these wands, their two counter-rotating brushes allow for all the carpet fibres to be lifted and cleaned from all sides. This removes the dirt from the base of the fibres and even a very dirty carpet is left completely cleaned in a single pass. The carpet is left almost dry.

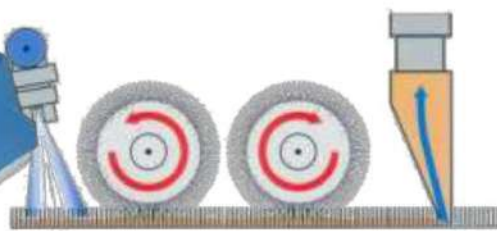

The

cleaning to accelerate the evaporation of any moisture left in the carpet. The carpet can be totally dry in a very short time. The features of the **ST810** include low-noise, high power (1Hp) and 3 working speeds. The integrated handle allows easy transportation from site to site.



ST810

Blower



Professional SETS



Santoemma **Professional SETS** are obtained by adding a series of special options to the Santoemma machines. These enhance the cleaning performance of the machine and ensure: excellent cleaning results, speed and ease of the cleaning operation, short drying time and slow re-soiling of the carpet after cleaning. Even dirty carpets are cleaned in a single pass and can be dry in one hour. All the cleaning factors are combined in an optimised way: chemical action, temperature, mechanical brushing action, time and vacuuming. Santoemma Professional SETS are available in different sizes to suit any area and are the most effective answer to the professional carpet cleaning problem.

Up to 180 sqm/h

Sabrina-Maxi with hoses, wand NS300-M, SMARTKIT system

Instant heater HT1800

Power brush tool NS270BRUSH

Hand tool NS10PN-M

Up to 350 sqm/h

Aluminium hand tool NS10ALL-M



DEMO VIDEO AVAILABLE

SMARTKIT System

Grace-Silent with hoses, Instant wand NS300-M, HT1800 and heater HT1800 SMARTKIT system

Power brush tool NS400BRUSH

Power brush tool NS400BR-DUAL / NS400BR-DUAL-HT

Up to 350 sqm/h

Instant Heater

HT1800

**Charis-DUAL with
SMARTKIT system**

Wand NS300

**Hand tool
NS10PN-M**

Self-contained machines

11



Self-contained machines incorporate the cleaning unit below the machine body. The operator moves the machine on the carpet surface, cleaning parallel floor areas, which achieves higher performance in terms of square meters cleaned in one hour. External tools can also be used to clean hard-to-reach areas.

Up to
120
sqm/h



The **Sharon-Brush** is a self-contained machine with a rotating brush, designed for professional cleaning of small areas of carpet and hard floors. A special device allows for switching from carpet to hard floor cleaning by simply turning a knob. The rotating brush, with automatic pressure adjustment, is able to deep clean both very dirty carpets and hard floors. Its small width (only 29 cm) also allows the machine to be used in very narrow rooms. The water-flow can be adjusted for a maintenance low-moisture cleaning or a restoration deep-cleaning. It is possible to connect the hand tool NS10PN to the machine for cleaning armchairs and hard-to-reach spots. The Sharon-Brush is also suited for renting to private users thanks to its strength and its easy usage. Its professional features also make Sharon-Brush suitable for cleaning companies to use.

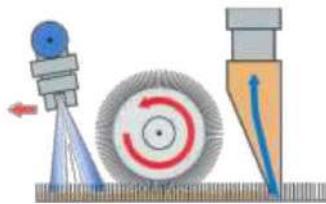

Carpet

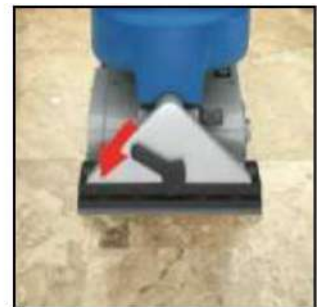

Hard floor



DEMO
VIDEO
AVAILABLE



Spray control



Easy brush replacement



Self-contained machines



Up to
250
sqm/h

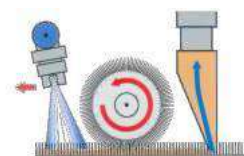

The **Charis-ONE** is a self-contained machine, for cleaning middle sized carpeted areas. With Charis-ONE it is possible to clean a 40cm strip of carpet perfectly, removing the dirt from the base of carpet fibres.

The water-flow can be adjusted, for a **maintenance** low-moisture cleaning or a **restoration deep cleaning**.

The Santoemma **high waterlift** vacuum system allows excellent removal of the dirt and a very short drying time: the carpet can be dry in one hour! With only a 60 decibel sound level, it is possible to work without disturbing other people.

SMARTKIT System

Adding the patented **SMARTKIT** system to Charis-ONE or to Charis-DUAL, makes it possible to perform carpet **pre-spraying** with a concentrated chemical solution, **automatic chemical dosing** and **carpet rinsing**. The chemical is put in a bottle and the machine's tank contains only clean water. When the chemical solution is required, the machine automatically introduces the chemical in a measured quantity. This ensures the optimal chemical concentration, either during carpet extraction cleaning or in carpet pre-spraying.

During **extraction cleaning with a chemical**, a controlled chemical concentration is ensured, with no need for the operator to perform any dilution. Incorrect chemical concentrations and chemical wastage are avoided.

Using a dedicated pre-spray hose and gun, it is possible to pre-spray the carpet with a concentrated chemical solution. Pre-spraying a carpet with this solution allows a longer contact time for the chemical which helps to release the dirt from the carpet fibres. With the **SMARTKIT**, it is also possible to let the machine work with clean water only, in order to rinse the carpet fibres. This removes any sticky chemical residue left in the carpet and ensures a slow re-soling after cleaning.



Self-contained machines

13



Charis-DUAL is a patented self-contained machine for cleaning middle sized carpeted areas, with several innovative features. With the Charis-DUAL it is possible to clean a 40cm strip of carpet perfectly in a single pass and thanks to its **2 counter-rotating brushes** it removes the dirt from the base of carpet fibres. The water-flow can be adjusted, for a **maintenance low-moisture cleaning** or a **restorative deep cleaning**.

The Santoemma **high waterlift** vacuum system allows an excellent removal of dirt and a very short drying time: the carpet can be dry in 1 hour! With only a 60 decibel sound level, it is possible to work without disturbing other people.

The patented "**CLICK**" system allows the machine to manoeuvre in the lightest way and it is possible to work for many hours without much effort. With the Charis-DUAL it is possible to perform a deep **pre-brushing** of the carpet before extraction cleaning, which is useful for very dirty carpet areas.

Adding the patented **SMARTKIT** system to Charis-DUAL makes it possible to perform carpet **pre-spraying** with concentrated chemical solution, **automatic chemical dosing** and **carpet rinsing**.



The Charis-DUAL patented "CLICK" system

After cleaning a strip of carpet in a backward motion, all is needed is to slightly push the handle down and special support wheels will raise the machine. The machine can then easily slide forward to the beginning of next strip and there is no effort from the operator. It is not necessary to bend the machine back towards the operator and push it forward keeping it balanced on the rear wheels, as it usually happens with all pull-back extractors on the market.



CLEANING

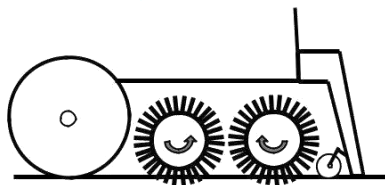

MOVING FORWARD

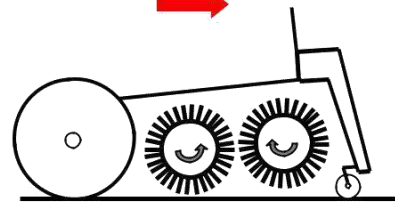



Self-contained machines

Carpet pre-brushing and cleaning with just one machine

With the Charis-DUAL it is also possible to perform a **deep pre-brushing** of the carpet before extraction cleaning commences. Normally this operation requires a dedicated machine, such as a single disk rotary machine. With the Charis-DUAL all these functions can be done with just one machine: Pre-brushing and Cleaning.

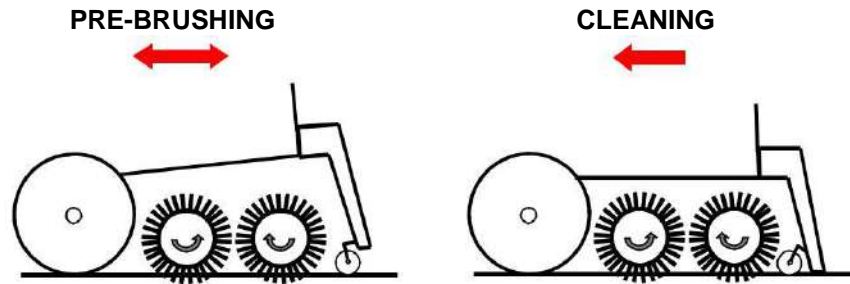

Carpet cleaning moving forward

An optional vacuum head allows cleaning the carpet by walking forward. Moving forwards may be preferred when it is necessary to clean carpet in particularly long corridors.



CARPET CLEANING MOVING FORWARD

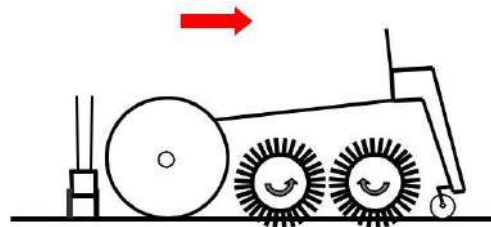

Hard floor cleaning

The optional squeegee **SQ720E** enables **hard floor cleaning** moving forward. The Charis-DUAL is transformed into a powerful scrubber drier, with 2 cylindrical brushes. Extra brushes, specific for hard floor cleaning, are also available.



HARD FLOOR CLEANING

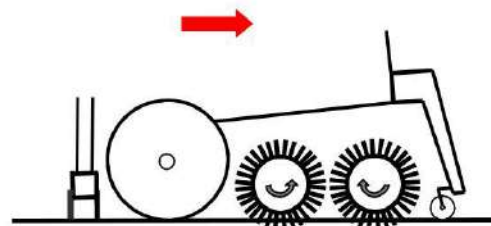

Self-contained machines

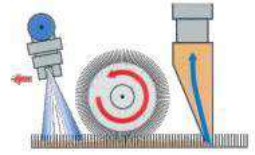

The **Elite-Silent** is a self-contained, manual traction machine for carpet and hard floor. It washes, brushes and dries a strip of carpet 50 cm wide. Moving forward it cleans up to **500 square metres** in one hour.

The 3 stage **high-waterlift** vacuum system allows the machine to dry a carpet very efficiently. The Elite-Silent is a very quiet machine, since it works with a 60 Decibels sound level only.

It is possible to adjust the brush and vacuum head pressure according to the type of carpet. The water-flow can be regulated, for a **maintenance** low-moisture cleaning or a **restorative deep cleaning**.

The Elite-Silent can be supplied with the instant hot water unit HT1800. If equipped with the patented SMARTKIT system, it is possible to perform automatic chemical dosing, carpet pre-spraying and rinsing. The optional squeegee SQ720E allows for hard floor cleaning. An extra brush, specific for hard floor cleaning, is also available.



Optional squeegee for hard floor cleaning

Optional Squeegee for hard floor





Self-Contained machines

Up to
600
sqm/h



The **Powerful-Silent** is a self-propelled machine designed to clean very large areas of carpeting. It washes, brushes and dries a strip of carpet 50cm wide, moving forward with adjustable speed, cleaning up to 600 square metres in 1 hour. The differential drive motor allows the machine to turn without effort, giving it good manoeuvrability even in narrow areas, for example in corridors. The pressure of the rotating brush can be adjusted, according to the type of carpet. The water-flow can be regulated for a maintenance low-moisture clean or a restorative deep clean.

The Powerful-Silent can be supplied with the instant hot water unit HT1800. If equipped with the patented SMARTKIT system, it is possible to perform automatic chemical dosing, carpet pre-spraying and rinsing. The optional squeegee SQ720E allows for hard floor cleaning. An extra brush, specific for hard floor cleaning, is also available.

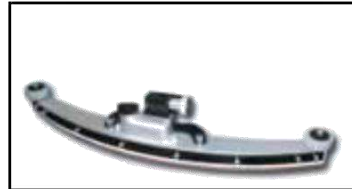
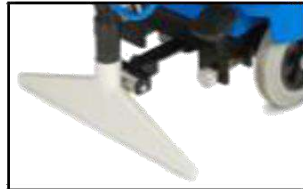

The **Elite-Battery** is a battery powered self-contained machine for cleaning large areas of carpet. It washes, brushes and dries a strip of carpet 50cm wide while moving forward. Without a power cord, it is easy to operate in large areas, for example in hotels, shopping centres, airports and convention halls. The Elite-Battery is a very quiet extractor, since it works with a 60 decibel sound level only. It is possible to adjust the brush and vacuum head pressure, according to the type of carpet. The water-flow can be regulated, for a maintenance low-moisture cleaning or a restoration deep-cleaning.

Equipped with the patented SMARTKIT system, it is possible to perform automatic chemical dosing, carpet pre-spraying and rinsing. The optional squeegee SQ720E allows for hard floor cleaning. An extra brush, specific for hard floor cleaning, is also available.



Self-contained machines



17

Up to
1000
sqm/h

Nikita is a step-on carpet cleaning machine. It is ideal for very large areas of carpeting and is able to clean up to **1000 square metres** of carpet in 1 hour. With a single pass, a 70cm strip of carpet is sprayed with a concentrated chemical solution, brushed with two counter-rotating brushes, rinsed and vacuumed.

With 2 three stages high-waterlift vacuum motors, Nikita can leave the carpet almost completely dry after the cleaning process. It is possible to perform a maintenance low-moisture cleaning or a restorative deep-cleaning. The pressure of the brushes and of the vacuum head is adjustable according to the carpet type.

Turning a lever and using a specific chemical, Nikita can be used to clean the carpet with the **"Encapsulation"** cleaning system.

Moreover with the optional squeegee SQ900N, Nikita can be transformed into a **powerful step-on scrubber drier**.

The machine is equipped with a differential drive motor that gives it excellent manoeuvrability in any place.



DEMO
VIDEO
AVAILABLE





Foam Extraction machines



Some surfaces, like upholstery or areas with carpets or rugs near room entrances can be cleaned with foam, instead of with a solution of water and chemical. Thanks to the special Santoemma **DENSE FOAM** technology, available on some models of the range, it is possible to clean such surfaces with foam. The dense foam is spread on the surfaces, brushed and after some seconds vacuumed up. Unlike a normal solution of water and chemical, the dense foam does not penetrate deep inside the fibres, but it acts only on the superficial layer, where most of the dirt settles. The foam extraction system allows achieving excellent cleaning results and an extremely short drying time.

In order to obtain the special dense foam, the chemical solution is mixed with compressed air, obtained by a dedicated air compressor in the machine. The quality of the foam is therefore much better than the “liquid foam” of machines without a compressor. Thanks to its optimal density, dense foam does not remain on the surface of textiles, as it happens with “dry foam”, but it penetrates a few millimetres into the superficial layer of the textile where the dirt lies, assuring excellent cleaning results.

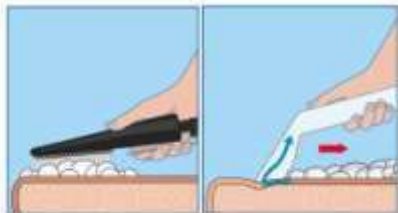

Foam extraction upholstery cleaning

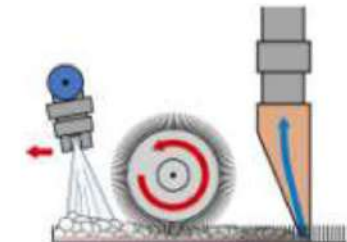

Foam extraction carpet cleaning



The **Sabrina-Foam** is a foam extraction machine, with an internal compressor. It sprays a special dense foam on the surface that is to be cleaned, either being carpet or upholstery. The foam density is adjustable. Sabrina-Foam can also work as an injection-extraction machine. Its high-waterlift vacuum system allows the recovery of the maximum quantity of dirt from the carpet and upholstery. It also achieves the shortest drying time possible.

Sabrina-Foam can also be used with the power-brush tool NS270BRUSH, in order to get a better cleaning result, thanks to the mechanical action of the cylindrical brush.



HOT-Sabrina-Foam is a foam extraction machine, with an internal compressor. Thanks to a Santoemma **patented system**, the machine is able to spray the special **hot dense foam** on the surface that is to be cleaned. Hot foam is even more effective than room temperature foam and allows even a shorter drying time. The foam is instantly heated as soon as the machine is switched on and the foam density is also adjustable.

The HOT-Sabrina-Foam can work also as a **hot injection-extraction machine**. Its **high -waterlift** vacuum system allows the recovery of the maximum quantity of dirt from carpet and upholstery and to get the shortest drying time possible. The HOT-Sabrina-Foam can also be used with the power-brush tool NS270BRUSH, in order to get a better cleaning result, thanks to the mechanical action of the cylindrical brush.



Model Summary

19

Cleaning systems and models

Some models can work with different systems, depending on the application and the operator's preferences. For box extractors, the rotating brush action can be obtained by connecting the machine to an optional power brush wand. The following table shows the cleaning systems for each model.

Cleaning Systems Models	Injection Extraction	HOT Injection Extraction	Injection Extraction + brushing	Foam Extraction	HOT Foam Extraction	Foam Extraction + brushing
Sabrina	x		With optional NS270BRUSH			
Sabrina-HOT	x	x	With optional NS270BRUSH			
Sabrina-Maxi	x	With optional HT1800	With optional NS270BRUSH			
Serena-Silent	x	With optional HT1800 NS400BR-DUAL-HT	With optional NS400BRUSH			
Grace-Silent	x	With optional HT1800 NS400BR-DUAL-HT	With optional NS400BR-DUAL NS400BR-DUAL-HT			
GraceHP-Silent	x	With optional HT1800-HP NS400BR-DUAL-HT	With optional NS400BR-DUAL NS400BR-DUAL-HT			
Sharon-Brush	x		x			
Charis-ONE / DUAL	x	With optional HT1800	x			
Elite-Silent	x	with optional HT1800	x			
Powerful-Silent	x	With optional HT1800	x			
Elite-Battery	x		x			
Nikita	x		x			
Sabrina-Foam + wand	x		With optional NS270BRUSH	x		With optional NS270BRUSH
HOT-Sabrina-Foam + wand	x	x	With optional NS270BRUSH	x	x	With optional NS270BRUSH
NS270BRUSH			x			With Sabrina-Foam HOT-Sabrina-Foam
NS400BRUSH			x			
NS400BR-DUAL			x			
NS400BR-DUAL-HT		x	x			
T-CLEAN chemical	x	x	x			
T-FOAM chemical				x	x	x



Accessories and chemicals



NS10PN
Transparent plastic hand tool



NS10ALL
Aluminum hand tool



HERMES
Walls and windows tool



NS270N
Carpet and hard floor wand

NS300
Carpet wand with 3 nozzles

NS270P
accessory for hard floor, walls, windows and ceilings

NS400P
accessory for hard floor cleaning



T-CLEAN

It is a special non-foaming chemical for textiles to be used with injection-extraction machines.



T-FOAM

It is a special foaming chemical for textiles to be used with foam-extraction machines. T-FOAM contains strong cleaning agents that remove the dirt and inhibits re-soiling. It performs an efficient bactericide action.



ANTI-FOAM

It is a de-foamer to be used with injection-extraction and foam-extraction machines.



The **STAIN REMOVAL KIT** contains three professional chemical for removing the majority of the most stubborn stains from carpet and fabrics:

- **BIO-ENZYME:** Enzyme digester chemical and deodoriser for carpets, upholstery and mattresses. It removes food, grease, vomit, blood, organic residuals and protein stains, leaving a pleasant perfume.
- **COFFEE STAIN REMOVER:** chemical for the removal of coffee, tea, red wine, fruit juice and highly coloured stains from carpet and fabrics.
- **ORANGE GEL:** thick gel solvent-base chemical for the removing of stains from carpet and upholstery. It removes oil, grease, chewing gum, tar and other stains, leaving a pleasant orange fragrance.

Carpet vacuuming

21

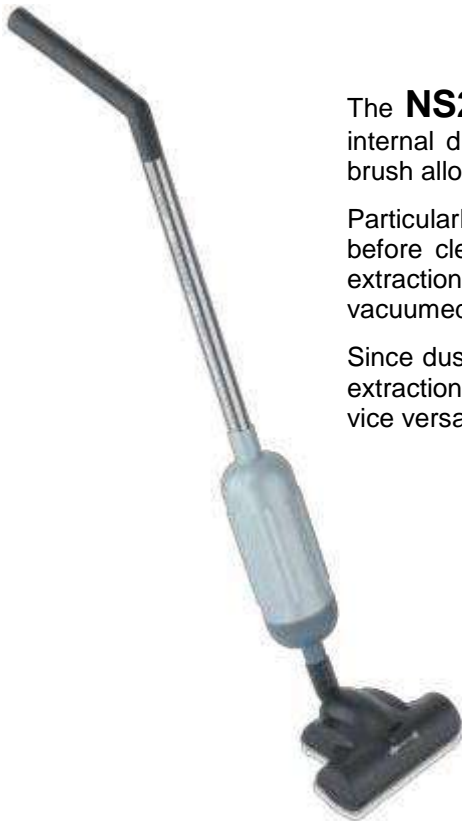

The **NS270TURBODUST** is an innovative vacuum tool. It has a rotating brush and internal dust bag, which allows vacuuming carpets with any extraction machine. Its rotating brush allows it to completely remove the dust from carpet fibres.

Particularly suitable for the Sabrina model, it can be used with any machine to vacuum carpets before cleaning. This tool has no brush motor, since the brush rotation is activated by the extraction machine's airflow. Also, no vacuum motor is contained inside the tool, since the air is vacuumed by the machine body. Therefore, it is extremely light to use.

Since dust is collected by the bag inside the tool, there is no need to make any change to the extraction machine before switching from injection-extraction cleaning to dust vacuuming and vice versa.

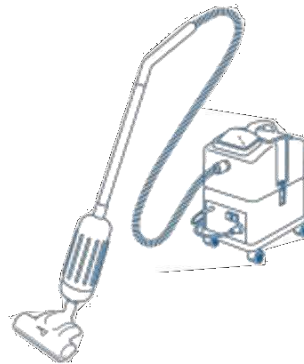

BT350 and BT450 are heavy-duty and reliable upright vacuum cleaners, with a cylindrical rotating brush, designed to vacuum carpet deeply. Two sizes are available, for cleaning large or smaller areas.

The action of the rotating brush allows to remove dust, sand and solid dirt residuals from the carpet fibres.

It is very important to use an upright vacuum cleaner with rotating brush on a daily basis, to maintain carpet in better conditions and extend the life time of the carpet as well. It is also an essential operation before carpet cleaning.

	BT350	BT450
Cleaning width:	350 mm	450 mm
Dust bag capacity	6,5 l	6,5 l
Full bag indicator:	electronic	electronic
Vacuum motor power:	800 W	800 W
Waterlift:	2500 mm H2O	2500 mm H2O
Air flow:	Max 43 l/sec	Max 43 l/sec
Exhaust air filtering system:	- Standard: washable filter - Optional HEPA filter	- Standard: washable filter - Optional HEPA filter
Brush motor:	200W 5000 rot/min	250W 4000 rot/min
Transmission belt:	POLY-V belt	POLY-V belt
Brush height adjustment	4 positions	4 positions
Electronic clutch control board + worn-out brush:	standard	standard
Cable length:	10 m	10 m

Technical data and performance

	Sabrina	Sabrina-Hot	Sabrina-Maxi	Serena-Silent	Grace-Silent	GraceHP-Silent
Approx performance (basic machine)*:	25-45 m ² /h	40-60 m ² /h	40-80 m ² /h	45-90 m ² /h	50-100 m ² /h	60-110 m ² /h
Approx performance (professional SET)*:	50-100 m ² /h	60-120 m ² /h	130-180 m ² /h	150-200 m ² /h	160-220 m ² /h	170-240 m ² /h
Recovery tank:	14 litres	14 litres	30 litres	50 litres	70 litres	70 litres
Solution tank:	14 litres	14 litres	30 litres	50 litres	70 litres	70 litres
Vacuum motor: Power: Max. waterlift (mm H ₂ O): Max. air flow (l/sec.):	2 stages HW 1500 W 3000 50	2 stages HW 1500 W 3000 50	2 stages HW 1500 W 3000 50	3 stages HW 1500 W 3400 45	2 x 3 stages HW 2 x 1500 W 3400 90	2 x 3 stages HW 2 x 1500 W 3400 90
Pump with bypass: Power: Max pressure: Max. water flow:	vibrating 70 W 4 bar 1,5 l/min.	vibrating 70 W 4 bar 1,5 l/min.	membrane 80 W 9 bar 4,5 l/min	membrane 80 W 9 bar 4,5 l/min	membrane 80 W 9 bar 4,5 l/min	Piston 180W 28 bar (adjust) 4,5 l/min
Cleaning width:	270/290 mm	100 mm	300 mm	300 mm	300 mm	300 mm
Number of nozzles:	1	1	3	3	3	3
Adjustable pressure:	-	-	-	-	-	YES
Instant heating system:	-	Standard 1800W	Optional HT1800	Optional HT1800	Optional HT1800	Optional HT1800-HP
Rotating Brush:	Optional NS270BRUSH	Optional NS270BRUSH	Optional NS270BRUSH	Optional NS400BRUSH	Optional NS400BR-DUAL NS400BR-DUAL-HT	Optional NS400BR-DUAL NS400BR-DUAL-HT
Automatic dosing system:	-	-	Optional SMARTKIT-MX	Optional SMARTKIT-EL	Optional SMARTKIT-EL	Standard
Pre-spray system:	-	-	Optional PRESPRAY-MX	Optional PRESPRAY-EL	Optional PRESPRAY-EL	Standard
Cable length:	10 m	10 m	10 m	10 m	10 m	10 m
Hoses length:	2,5 m	2,5 m	5 m	5 m	7,5 m	7,5 m
Weight (machine body):	12 Kg	22 Kg	24 Kg	43 Kg	55 Kg	80 Kg
Weight (packaged machine):	15 Kg	25 Kg	33 Kg	55 Kg	70 Kg	95 Kg
Dimensions:	30x42x53 cm	30x42x66,5 cm	38x50x78cm	44x86x94 cm	50x89x98 cm	50x89x98 cm
Package dimensions:	34x53x70 cm	36x60x80 cm	42x65x91 cm	54x94x98 cm	54x94x98 cm	60x95x112cm
Units/pallet	15 pcs/ pallet (88x120x223h)	15 pcs/ pallet (88x120x223h)	8 pcs / pallet (84x130x194h)	4 pcs / pallet (94x120x210h)	4 pcs / pallet (94x120x210h)	1 pc / pallet (60x95x112h)
Voltage:	230-240V 50-60Hz (available versions at 100V or 120V 50-60Hz)					
Standard colour:	Blue					
Tanks construction:	High density polyethylene					

*The effective performance depends on the type of cleaning required: restorative deep cleaning - maintenance cleaning.

Technical data and performance

23

	50-120 m²/h	120-250 m²/h (ONE) 150-300 m²/h (DUAL)	250-500 m²/h	300-600 m²/h	250-500 m²/h	500-1000 m²/h
Approx performance (professional SET)*:	-	200-300 m²/h (ONE) 230-350 m²/h (DUAL)	340-550 m²/h	370-650 m²/h	300-550 m²/h	-
Recovery tank capacity:	12 litres	35 litres	50 litres	70 litres	50 litres	70 litres
Solution tank capacity:	12 litres	35 litres	50 litres	70 litres	50 litres	70 litres
Vacuum motor: Power: Max. waterlift (mmH ₂ O): Max. air flow (l/sec.):	2 stages 1000 W 2200 50	3 stages HW 1500 W 3400 45	3 stages HW 1500 W 3400 45	2 x 3 stages HW 2 x 1500 W 3400 90	3 stages HW 850 W 2500 45	2 x 3 stages HW 2 x 850 W 2500 90
Pump with bypass: Power: Max pressure: Max. water flow:	vibrating 70 W 4 bar 1,5 l/min.	membrane 80 W 9 bar 4,5 l/min	membrane 80 W 9 bar 4,5 l/min	membrane 80 W 9 bar 4,5 l/min	membrane 80 W 9 bar 4,5 l/min	membrane 80 W 9 bar 4,5 l/min
Cleaning width (carpet/floor):	270/290 mm	400 mm	500/720 mm	500/720 mm	500/720 mm	700/900 mm
Number of nozzles:	3	4 (ONE) 5 (DUAL)	5	5	5	6+3
Adjustable water-flow:	YES	YES	YES	YES	YES	YES
Instant heating system:	-	Optional HT1800	Optional HT1800	Optional HT1800	-	-
Rotating Brush:	90W 600 rot/min 232 mm	1x120W (ONE) 2x120W (DUAL) 600 rot/min 363 mm	90W 600 rot/min 464 mm	90W 600 rot/min 464 mm	250W 840 rot/min 464 mm	2 x 100W 840 rot/min 604 mm
Driving motor:	-	-	-	90W with differential	250W with differential	350W with differential
Automatic dosing system:	-	Optional SMARTKIT-CH	Optional SMARTKIT-EL	Optional SMARTKIT-EL	Optional SMARTKIT-EL	Integrated
Pre-spray system:	-	Optional PRESPRAY-MX	Optional PRESPRAY-EL	Optional PRESPRAY-EL	Optional PRESPRAY-EL	Integrated
Cable length:	10 m	15 m	15 m	15 m	-	-
Hoses length:	2,5 m	Optional	Optional	Optional	Optional	Optional
Weight (machine body):	21,5 Kg	50 Kg (ONE) 58 Kg (DUAL)	62 Kg	87 Kg	184 Kg Incl. batteries	334 Kg Incl. batteries
Weight (packaged machine):	25 Kg	65 Kg (ONE) 73 Kg (DUAL)	77 Kg	102 Kg	205 Kg Incl. batteries	390 Kg Incl. batteries
Dimensions:	29x78x90 cm	42x104x96cm	50x86x95cm	50x92x102 cm	50x89x119cm	70x120x135 cm
Package dimensions:	36x60x80 cm	50x110x112cm	60x95x112cm	60x95x122 cm	65x102x135cm	80x123x160 cm
Units/pallet:	8 pcs/ pallet (80x120x165h)	1 pc / pallet (50x110x112h)	1 pc / pallet (60x95x112h)	1 pc / pallet (60x95x122h)	1 pc / pallet (65x102x135h)	1 pc / pallet (80x123x160 cm)
Batteries:	-	-	-	-	3 x 12V 100Ah Tot 90 Kg	6 x 12V 75Ah Tot 160 Kg
Voltage:	230-240V 50-60Hz (available versions at 100V or 120V 50-60Hz)				Available with charger at 100/120/240V	Available with charger at 100/120/240V
Standard colour:	Blue					
Tanks construction:	High density polyethylene					

*The effective performance depends on the type of cleaning required: restorative deep cleaning - maintenance cleaning.

Technical data and performance

	Sabrina-Foam	HOT-Sabrina-Foam
Approx. performance	20-30 seats/hour	20-30 seats/hour
Recovery tank capacity:	14 litres	14 litres
Solution tank capacity:	14 litres	14 litres
Vacuum motor: Power: Max. waterlift (mm H ₂ O): Max. air flow (l/sec.):	2 stages HW 1500 W 3000 50	2 stages HW 1500 W 3000 50
Pump with bypass: Power: Max pressure: Max. water flow:	vibrating 70 W 4 bar 1,5 l/min.	vibrating 70 W 4 bar 1,5 l/min.
Compressor:	350W	350W
Cleaning width (hand tool /NS270BRUSH):	100/270 mm	100/270 mm
Number of nozzles (hand tool /NS270BRUSH):	1 / 3	1 / 3
Instant heating system:	-	1800W
Dilution rate:	1 part detergent 4 parts water	1 part detergent 4 parts water
Solution consumption (water + chemical)	30-40 grams/seat	30-40 grams/seat
Cable length:	10 m	10 m
Hoses length:	2,5 m	2,5 m
Weight (machine body):	35 Kg	50 Kg
Weight (packaged machine, including 10 Kg of chemical):	52 Kg	67 Kg
Dimensions:	32x55x86 cm	32x55x99 cm
Package dimensions:	42x65x100 cm	42x65x100 cm
Units/pallet:	1 pc/ pallet (42x65x100h)	1 pc/ pallet (42x65x100h)
Voltage:	230-240V 50-60Hz (available versions at 100V or 120V 50-60Hz)	
Standard colour:	Blue	
Tanks construction:	High density polyethylene	

*The effective performance depends on the type of cleaning required: restorative deep cleaning - maintenance cleaning.