

4-wheeled container systems

# MGB 1100 FD

## Flat lid



# MGB 1100 FD

## Material and Design

- Polymer components injection moulded from specially designed HDPE
- Resistant to decay, frost, heat and many chemicals
- Special UV-stabilisation provides excellent ageing characteristics
- Additives are cadmium free and environmentally friendly
- Metal components are corrosion resistant
- Quiet-running solid rubber tyres
- Compatible with identification and weighing systems
- Fitted as standard with chip nest in accordance with RAL GZ 951/1
- High quality materials and most advanced manufacturing processes guarantee a long service life
- All container parts are recyclable

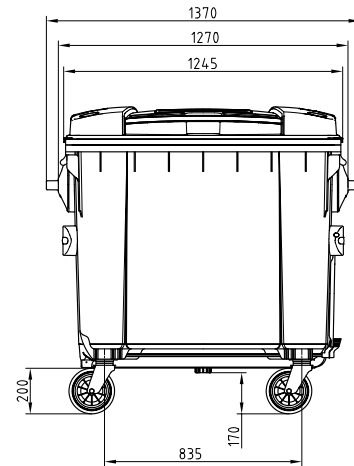

## Quality

- Certified according to EN 840 and RAL GZ 951/1
- Constant quality control through own laboratory as well as independent institutes

## Safety and Handling

- Large lifting trunnions with steel insert for increased safety during emptying
- Double angle rail for highest safety during emptying with comb lifting devices
- Easy-grip handles on all sides of the body
- Safe, easy handling, even with heavy loads
- Reinforced base and front and rear panels for highest stability
- Various wheel assembly configurations for different applications
- Special ribs prevent containers from becoming jammed when stacked
- Easy-grip handles on the front and sides of lid for easy filling
- Stable and lightweight lid
- Rounded lid profile for improved rainwater dispersal
- No water ingress when opening the lid
- Easy to clean due to smooth surfaces and rounded internal corners

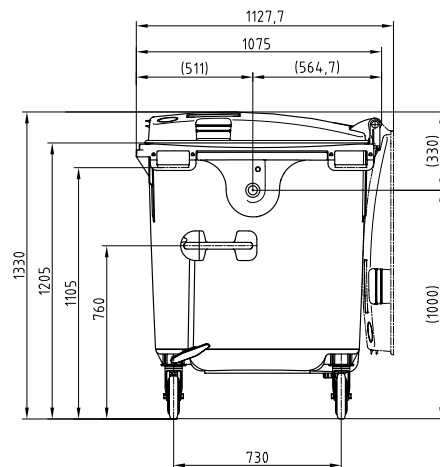

all dimensions may vary due to production conditions

## Colours

- Standard colours grey, green, blue and yellow
- Special colours are available on request

## Accessories

- Comprehensive range of accessories in separate brochure

## Specifications

Nominal volume	Net weight	Max. load	Permitted total weight
1100 litres	ca. 65 kg	440 kg	510 kg

